

**COOK COUNTY/GRAND MARAIS EDA AGENDA**

**TUESDAY, APRIL 6, 2021, 4:00 PM**

**TO BE HELD ELECTRONICALLY VIA ZOOM, SEE ATTACHED LINK**

*The mission of the Cook County/Grand Marais EDA is to diversify the economy, create employment through retention and expansion of existing businesses, and development of new businesses, support the development of housing and increase the tax base.*

- 4:00 PM      **CALL TO ORDER**  
Public Comments – if any received prior to the meeting  
Adjustments to and approval of the Agenda (motion)  
Approval of March 9, 2021 Minutes (motion) *Page 2*
- 4:10 PM      **NEW BUSINESS – (motion for each item, except Bluefin, if approved)**  
Bluefin development project – information only  
Consider Finance Committee recommendation for TABR Loans *Page 7*  
Consider requests for Business Development Funds  
*Page 8* The Fisherman's Daughter and Grand Portage Trading Post *Page 15*  
Consider Resolution - IRRR Demolition Grant – Metis Housing Project *Page 20*  
Consider Resolution – IRRR Development Infrastructure – CCHS *Page 21*  
Consider 2021 Budget for Superior National at Lutsen
- 5:10 PM      **FINANCIALS**  
Superior National and EDA Financials (forward to audit)  
EDA payments (motion)
- 5:30 PM      **OLD AND ONGOING BUSINESS – UPDATES AS NEEDED**  
GM Fire Redevelopment  
Housing and Redevelopment Authority  
Assisted Living/Senior Housing  
Cook County Workforce Solutions  
Cedar Grove Business Park  
Creative Economy Collaborative  
Succession Planning – Personnel Committee  
SBDC Director's Report *Page 22*  
Executive Director's Report *Page 23*
- 5:45 PM      Other as needed, next meeting May 11, 2021, WTIP interview

**Cook County-Grand Marais Economic Development Authority**  
**March 9, 2021 – meeting conducted via Zoom**

**Present:** Board members Scott Harrison, Howard Hedstrom, Bev Green, Carol Mork, Ann Sullivan, Virginia Palmer, Anton Moody

**Others present:** Executive Director Mary Somnis, Small Business Development Center Representative Pat Campanaro, County Administrator James Joerke, and minute taker Rhonda Silence

Meeting called to order by EDA President Howard Hedstrom at 4:00 p.m.

**Public Comment** – none

**Agenda & Minutes**

Agenda reviewed. Executive Director Mary Somnis asked to add two items to the agenda— appointment of an EDA member to the personnel committee and discussion of the EDA website. *Motion by Carol Mork second by Scott Harrison to approve the agenda with those additions. Motion carried, all ayes.*

Minutes of February 9, 2021 meeting reviewed. *Motion by Carol Mork, second by Ann Sullivan to approve February 9, 2021 minutes. Motion carried, all ayes.*

Minutes of February 23, 2021 minutes reviewed. *Motion by Bev Green, second by Carol Mork, to approve the February 23 minutes. Motion carried, all ayes.*

**NEW BUSINESS**

**Consider rescheduling April 13 meeting**

Director Somnis asked the EDA board to consider rescheduling the April 13 meeting to April 6. The board agreed and the meeting will be held on April 6 at 4 p.m.

**Consider request for Business Development Funds**

Director Somnis said this is pending and will be brought back before the EDA at the April meeting.

**Consider adding a board member to the finance committee**

Director Somnis said an EDA member needs to be added to the finance committee. Former Commissioner Heidi Doo-Kirk previously served on the committee. New Commissioner and EDA Board Member Ann Sullivan agreed to serve on the committee. She will be on the committee with Howard Hedstrom and Scott Harrison. The EDA board thanked her for taking on that position.

An EDA board member is also needed for the personnel committee. New Board Member Virginia Palmer agreed to serve on the committee. She will serve along with Howard Hedstrom and Carol Mork. The EDA board thanked her for taking on that position.

**EDA website**

Somnis said that Sandra Schutte of Two Dogs in the Web is no longer doing website work and maintenance. The EDA needs to make other arrangements for website hosting. Somnis recommended WA Fisher, a company she has worked with, and had good experience with, in the past. She said the cost for hosting is \$300 for a year. It will cost \$3,500 to convert the website to the WordPress format. Updating content would be \$18/hour.

The board directed Somnis to proceed with moving and updating the website, working with WA Fisher for one year.

### **Director Exit Strategy**

Somnis reminded the EDA board that it is time to begin succession planning. She provided the 2016 job description and announcement of a job opening for review. The EDA board will consider approval of the information at their next meeting, on Tuesday, April 6. Once approved, an advertisement will go out and interested parties will be asked to submit resumes. The board discussed how this should be handled and whether they should hire someone to facilitate posting, interviews, etc. The board agreed the current director should not be directly involved in the hiring process. They asked Somnis to set up a Zoom meeting for the personnel committee so they can decide how to proceed.

Somnis said she hopes that a successful candidate could be found and orientation started at the beginning of June. Somnis reassured the board that she will stay on until the board is comfortable with the transition. And, she agreed to stay on in some capacity, as needed to finish some current EDA projects.

### **FINANCIALS**

The EDA board reviewed the Superior National at Lutsen financials. Treasurer Scott Harrison said the golf course had good liquidity, but reminded the board that these funds need to cover payroll and expenses until after the golf course is up and running. But he commended the golf course staff for keeping expenses down and as an example said he had asked Heath Ekstrom to keep pro shop inventory low. Ekstrom dropping that budget item by \$24,000.

Harrison also reminded the board that the Grounds Superintendent Mike Davies is retiring. He said the golf course has talked to some interested people and they are hoping to get the top two up for a visit to the course.

Howard Hedstrom asked if the salary being offered is enough to entice quality applicants. Harrison said Mike Davies believes the salary is comparable, but benefits are not. However, Harrison said there is quality of life to be considered.

Harrison said the golf course will present its budget in April. He also reminded the EDA that there would be a time when the course will be paying two grounds supervisors. Somnis said the EDA budget is usually presented in March, but the EDA can wait until April by making a motion.

*Motion by Ann Sullivan, second by Bev Green, to postpone review and approval of the Superior National at Lutsen budget until April. Motion carried, all ayes.*

The EDA also reviewed the Cook County/Grand Marais Economic Development Authority financials for February 2021.

The golf course and EDA financial reports will be filed for the annual EDA audit.

The board reviewed the checks to be written for the invoices for the month. Somnis asked the EDA to approve one check that was not in the EDA packet, for \$4,000 to James Hammer. The EDA had previously approved a business development fund award to Hammer to establish a chimney sweep business. Hammer has purchased the necessary equipment and completed training and submitted the appropriate documentation.

*Motion by Bev Green, second by Carol Mork to approve checks for the January 2021 invoices as presented, with the addition of the check for James Hammer. Motion carried, all ayes.*

### **Old and Ongoing Business**

#### **Grand Marais Fire redevelopment**

Howard Hedstrom said there has been discussion with some developers. He said White Pine North is very anxious to get back in business with a storefront. There has been interest from another retailer and restaurateur. Hedstrom will continue to work on this.

#### **Taconite Area Business Relief Loans**

The loan application deadline for the Taconite Area Business Relief Loans is March 15. Small Business Development Center Consultant Pat Campanaro said 12 applications had been received so far. Scott Harrison suggested that the EDA committee reviewing the applications meet as soon as possible so decisions can be presented at the April 6 meeting. Campanaro will set up a meeting with Scott Harrison, Howard Hestrom, Ann Sullivan and Mary Somnis as soon as possible.

#### **Housing and Redevelopment Authority**

Somnis said exploration of setting up an HRA continues. This was discussed at the last local government leadership meeting. Somnis, County Administrator James Joerke and City Administrator Mike Roth continue to meet with Minnesota Housing Partners.

#### **Assisted Living**

Scott Harrison asked if progress on an assisted living facility had come to a halt. Somnis said she had received information on a grant opportunity for construction that she is pursuing. She said from what she has been hearing, many seniors just want a simple apartment-style facility, not one with nursing care. She said this may be a more attainable goal.

EDA Board Member Bev Green agreed that is what many people want. She said another issue is finding people to work in such a facility. She said Cook County's home health program is struggling to find staff. Green said worker housing continues to be a problem.

#### **Cook County Workforce Solutions –Pine Ridge, South Dakota**

Local business owner Sarah Hamilton is still working on recruiting workers from Pine Ridge. The EDA will work with her on this and can contribute \$13,000 to the effort. Somnis said the Lloyd K. Johnson Foundation has approved using the funding previously granted for this effort. A website is being set up and should be launched soon.

### **Cedar Grove Business Park**

Somnis said she continues to look for ways to help potential buyers with the cost of developing a storm water plan. She and City Administrator Mike Roth met with Ilena Hansel of Cook County Soil & Water. They recommended that the EDA work with Keith Anderson of Beaver River Consultants, who has done storm water work in Cook County.

Somnis said the EDA is applying for a DNR Coastal Zone grant to pay for his work. Somnis said a match is required, so the EDA may have to pay \$3,000.

Howard Hedstrom said he feels it is worth it, as Anderson will build a template for each lot, so a buyer will have some idea what to expect. The board agreed this would be really helpful.

Virginia Palmer noted that the Cedar Grove Business Park lots have not been marketed in the MLS system. She asked if the price of the lots could be increased, so the EDA could have funding to assist buyers with storm water plans.

Howard Hedstrom said there may be more interest in lot sales if the EDA can get the legislation passed to allow more owner-occupied lots. Board Member Anton Moody pointed out that the EDA has two owner-occupied lots available now and no one has expressed interest. Director Somnis said that is true, but she has had similar requests for lots that do not allow owner-occupied. She said the EDA has also had to say no to potential buyers because they do not meet the industrial/manufacturing/warehousing restrictions for lot sales. If passed, the legislation would also allow the EDA to change that covenant.

No matter what happens with the legislation, Palmer said the EDA could do a better job marketing the business park lots.

### **Arrowhead Animal Rescue/dog pound**

Somnis said there have been some comments on social media stating that a new dog pound, to replace the one being taken down at the Grand Marais Recreation Park, will be built in Cedar Grove Business Park. Somnis said this has been discussed, but no decisions have been made. Board Member Bev Green, who also serves on the board of Arrowhead Animal Shelter, said Sheriff Pat Eliassen has been working on this. She said there has been some design work and a contractor consulted. She said Arrowhead Animal Rescue is putting up a third of the money to build a new shelter.

For now, stray animals will be kept in the garage at the law enforcement center.

Somnis said she had talked to City Administrator Mike Roth and he said because of the storm water costs, the city may find another location.

### **Creative Economy Collaborative**

Somnis said the CEC has reached out to the Arrowhead Regional Development Center (ARDC) to see if that agency can provide staff support. Someone from ARDC will come to the next CEC meeting to discuss.

### **Small Business Development Center Report**

Small Business Development Center Consultant Pat Campanaro shared a written report for activities in February. She said much of her work has been with the team that developed the Minnesota Business Relief Grant Program and the Taconite Business Relief Loan Program.

Campanaro said the Success(ion) Planning workshop she is facilitating is going well, with seven businesses actively participating. She expressed appreciation to the EDA and Cook County Higher Education for helping to subsidize the workshop.

She reported that she had 35.25 regular consulting hours and 61 COVID-related hours.

**EDA Executive Director Report**

In addition to the agenda items already discussed, Somnis provided a memo with highlights of various committee, board, and community meetings she had attended or facilitated.

**OTHER BUSINESS**

The next EDA meeting will be April 6 at 4 p.m.

Mary Somnis will be available for an interview on WTIP on March 10.

*Meeting adjourned at 5:42 p.m.*

Respectfully submitted by  
*Rhonda Silence*  
*Minutes & More*

# memo

To: Cook County Grand Marais EDA Board  
From: TABR2 Loan Committee  
Date: March 29, 2021  
Re: TABR 2 Loan Application Report

Demand for the Taconite Area Business Relief Loan Program substantially outweighed available funding,

We received 34 applications totaling over \$425,000 for the \$215,000 in available funds.

The committee scored applications independently and then met to decide on final results.

While all applications had merit it was decided:

- We would award one loan per business which will allow us to work with more businesses
- Any application which scored 40 points or more would receive 90% of their original request.
- Any business scoring 30 points or more would receive 73% of their original request.

Using this criteria we will award 18 businesses \$215,100 in TABR 2 loans providing the Cook County Grand Marais EDA votes to approve the committees decision.

## **Loan Recipients:**

Cascade Vacation Rentals	Hedstrom Lumber	Well Spring Therapy
Lutsen Mountainside Lodge	JNS Custom Jewelers	Grand Marais Art Colony
Sivertson's Gallery	The Fisherman's Daughter	Mueller Studio
Fika	Voyageur Canoe Outfitter	Basecamp Bungalows
North House	Gunflint Mercantile	Voyageur Brewing
Lutsen Reflections	Joy Enterprises	Coldwater Foundation

**Business and Housing Subsidy Application:**

Business Name: The Fisherman's Daughter

Name of applicant: Abby Tofte and Kate Keeble

Address: 418 MN HWY 61, Grand Marais, MN 55604

Phone: Abby Cell: 218-220-9090 TFD Work: 218-387-2906

1) Describe your business, including such information as products and services provided, general market area served, experience or qualifications you have for operating this business, and any other information you feel may be appropriate:

\* see attached  
\_\_\_\_\_  
\_\_\_\_\_  
\_\_\_\_\_  
\_\_\_\_\_

2) Please check which criteria best describes your request:

Redevelopment

Projects that remove, prevent or reduce blight or other adverse conditions of property thereby protecting the City's and County's property values and the general public health, safety and welfare.

~~NBS~~ Attraction of New Business

Projects that attract or retain competitive and financially strong commercial and industrial companies, which offer the potential for significant growth in employment and tax base.

Highest and Best Use of Land

The use of the Business and Housing Funding will encourage quality construction and promote the highest and best use of the land, consistent with the comprehensive plans of the City and the County.

~~NBS~~ Needed Services

Projects that provide a needed service in the community, including health care, convenience and social services.

8



Unmet Housing Needs

Projects that provide housing needs not currently available in the community.

Economic Feasibility

The applicant must demonstrate that they have the experience and financing necessary for the project and that the project can be completed in a timely manner.

Job Creation

Projects that create and/or retain jobs which pay at least the higher of the current Federal or State of Minnesota minimum wage, plus appropriate benefits.

3) Amount Requested: \$15,000

4) Describe the proposed project: \*see attached  
\_\_\_\_\_  
\_\_\_\_\_  
\_\_\_\_\_

5) Please attach the project budget, including sources and uses of funds. \*see attached

6) Anticipated Completion Date: May 7, 2021

7) How many jobs do you anticipate will be created or retained by this project?

Created: \_\_\_\_\_ Retained: \_\_\_\_\_ Total: \_\_\_\_\_ \*see attached

8) What is the proposed wage/salary of the jobs?

Hourly: \_\_\_\_\_ Salary: \_\_\_\_\_ \*see attached

9

**COOK COUNTY/GRAND MARAIS EDA BUSINESS AND HOUSING FUNDING  
APPLICATION**

**The Fisherman's Daughter**

**1) Describe your business, including such information as products and services provided, general market area served, experience or qualifications you have for operating this business, and any other information you feel may be appropriate:**

The Fisherman's Daughter is an iconic Grand Marais food landmark. Carrying on the tradition of Harley and Shele Toftey's Dockside Fish Market, we excel in quick service fish and chips, smoked Lake Superior Fish, and locally caught fresh fish sold by the pound.

The Fisherman's Daughter opened in the summer of 2020, amidst the global pandemic and will continue in 2021 with major road construction directly in front of our business from mid-May through early October. We fought hard to keep true to our mission and values last year and will continue that fight in 2021. We will continue purchasing our baked goods from our local baker Hana Crosby, we will continue purchasing as much fresh fish as they will sell us from our downstairs neighbors North Superior Fisheries, and in 2021 we will add local produce from Creaking Tree Farms, drip and retail coffee from Fika Coffee and maple syrup from Lutsen! We will continue using our marketing platforms to promote and share the stories of our unique, and important local small business partners. Through this effort, we will reinforce the importance and impact of shopping local to our customers and staff.

**4) Describe the proposed project**

In June of 2020 we opened our window to customers for the first time. Due to the pandemic, we were not able to open our doors to the market, we operated out of a slider window our entire first season. We are extremely excited to open our DOORS in May of 2021. With the purchase of two large, energy efficient reach in deli-coolers, we plan to expand our menu to include many delicious, house-made deli items including (but not limited to) sandwiches, wraps, salads, bagels, dips and spreads.

With the addition of two deli coolers, we will take an extreme weight off of our need to fill line cook roles, which are notoriously hard to fill even in the best of times in Cook County. With an

increased focus on our deli cooler offerings, we are better able to utilize our deli/prep staff member's hours to make a big impact on our coolers and perhaps more importantly, give customers more quick options to fill their stomachs!

Our market space at The Fisherman's Daughter is tight. We will be following state guidelines by limiting the number of customers able to browse our market. Having customer friendly, reach in deli coolers will help speed up their shopping experience and then allow us to serve more customers in a day. Our hope is to make each customer's experience an enjoyable and efficient one, and these coolers will certainly aid in this endeavor.

Starting this year, we will be open year round at The Fisherman's Daughter. The addition of these deli coolers, and our expanded menu, will help fill a need in our community for quick service lunches. We will be a reliable source for on-the-go food options and dinner accompaniments, for both locals and tourists. Our consistent excellence in deli options will ensure we have year round hours for our employees.

**5) Please attach the project budget, including sources and uses of funds.**

Turbo Air Tom-50W-N 51" White Refrigerated Air Curtain Merchandiser: \$7,007.62

<https://www.webstaurantstore.com/turbo-air-tom-50w-n-51-white-refrigerated-air-curtain-merchandiser/902TOM50N.html>

Turbo Air TOM-60SW-N Slim Line 63" White Horizontal Air Curtain Display Case: \$6,487.87

<https://www.webstaurantstore.com/turbo-air-tom-60sw-n-slim-line-63-white-horizontal-air-curtain-display-case/902TOM60SN.html>

Addition of new electrical circuits to supply these coolers with power in the main market area:  
Estimate from Granite Electric as of 3/1/2021 \$1,500

Cooler: \$7,007.62

Cooler 2: \$6,487.87

Electrical Estimate: \$1,500

Total cost of project: **\$14,995.49**

**7) How many jobs do you anticipate will be created or retained by this project?**

We anticipate that at least 2 full time and 2 part time Deli/Prep positions will be made possible by this improvement to the business.

**Created:** 2 FT & 2 PT

**Retained:** We currently have approximately 11 Full Time positions and 4 Part Time Positions

**Total:** 13 Full Time, 6 Part Time

**8) What is the proposed wage/salary of the jobs?**

Tier 1: Seasonal Restaurant Workers, Cashiers \$12-\$13/hr + tips

Tier 2: Shift Managers, Year Round Deli/Prep, Back of House \$14-\$15/hr + tips

Tier 3: Upper Management Positions \$18-\$22/hr + tips

The implementation of these coolers purchased will affect all positions at The Fisherman's Daughter, but will directly impact the creation of more year round Deli positions in the Tier 2 level.

Hourly: \$14-\$15/hr + tips

Search 340,000+ products

< White Horizontal & Vertical Air Curtain Merchandisers

**Turbo Air TOM-50W-N 51" White Refrigerated Air Curtain Merchandiser**

Item #: 902TOM50N MFR #: TOM-50W-N

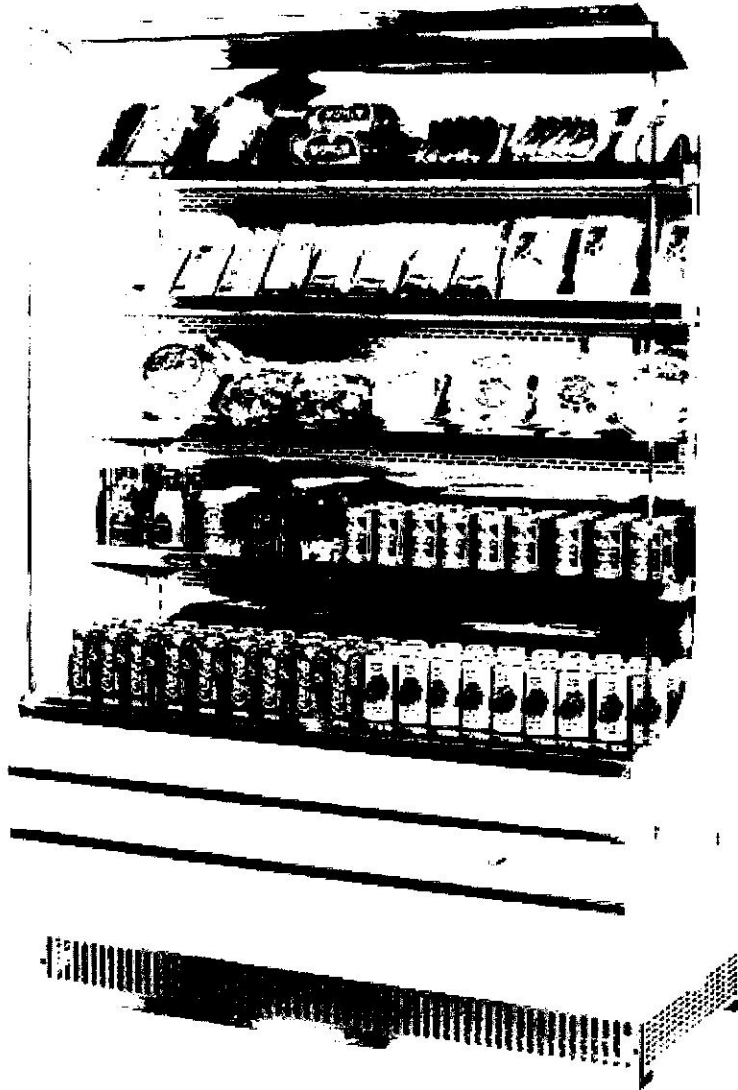

Only  
**\$7,007.62/Each**

13

Ships free with

Search 340,000+ products

◀ White Horizontal & Vertical Air Curtain Merchandisers

### Turbo Air TOM-60SW-N Slim Line 63" White Horizontal Air Curtain Display Case

Item #: 902TOM60SN MFR #: TOM-60SW-N

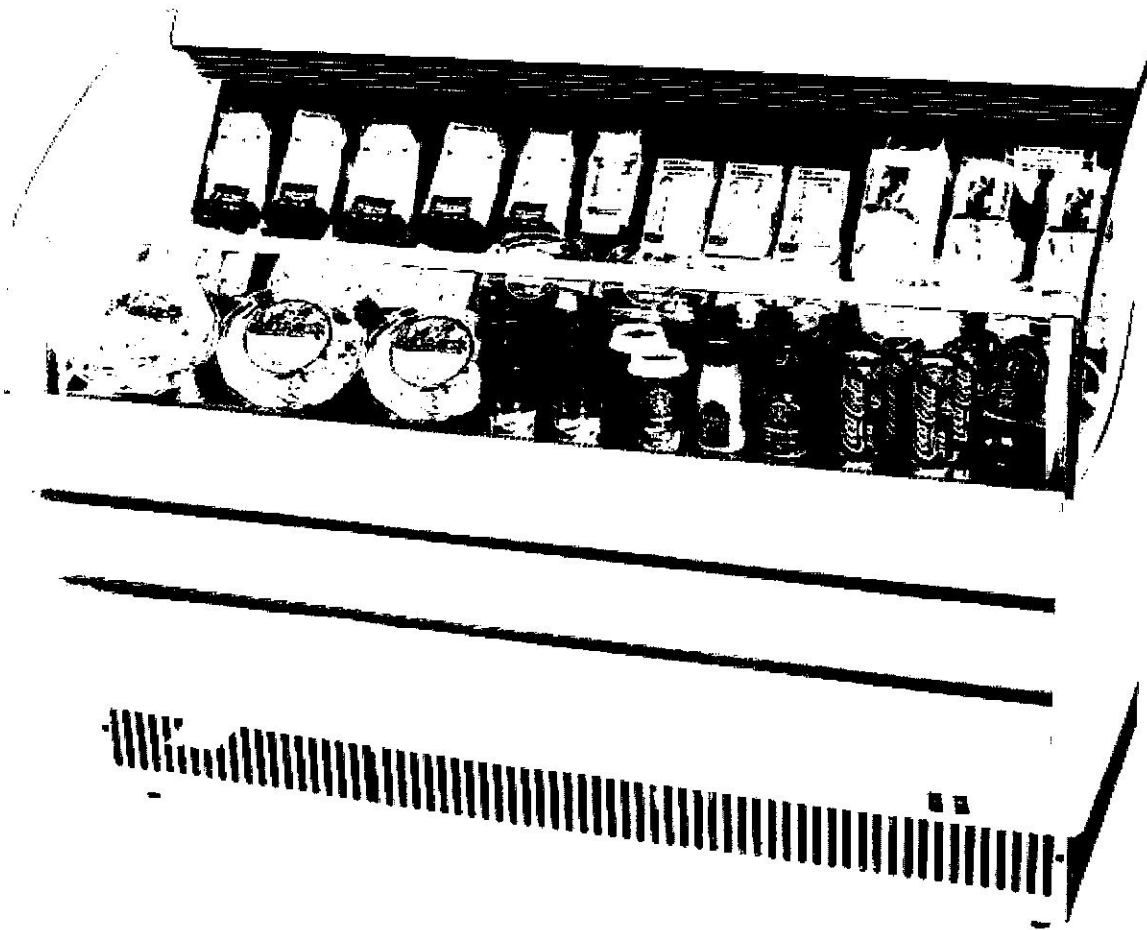

Only

**\$6,487.87**/Each

Ships free with

14

Protect Your Product with Safeware 

**Business and Housing Subsidy Application:**

Business Name: Grand Portage Trading Post

Name of applicant: Brian Sherburne

Address: P.O. Box 234, Grand Portage, MN 55605

Phone: 218-475-2938

1) Describe your business, including such information as products and services provided, general market area served, experience or qualifications you have for operating this business, and any other information you feel may be appropriate:

The Grand Portage Trading Post serves as a gas station, convenience store, but most importantly as a grocery store for the Grand Portage community. This store is the only access to groceries for those without means of travel. The Trading Post provide vital access to fresh produce, dairy and meats especially during Covid.

2) Please check which criteria best describes your request:

Redevelopment

Projects that remove, prevent or reduce blight or other adverse conditions of property thereby protecting the City's and County's property values and the general public health, safety and welfare.

Attraction of New Business

Projects that attract or retain competitive and financially strong commercial and industrial companies, which offer the potential for significant growth in employment and tax base.

Highest and Best Use of Land

The use of the Business and Housing Funding will encourage quality construction and promote the highest and best use of the land, consistent with the comprehensive plans of the City and the County.

Needed Services

Projects that provide a needed service in the community, including health care, convenience and social services.

Unmet Housing Needs

Projects that provide housing needs not currently available in the community.

Economic Feasibility

The applicant must demonstrate that they have the experience and financing necessary for the project and that the project can be completed in a timely manner.

Job Creation

Projects that create and/or retain jobs which pay at least the higher of the current Federal or State of Minnesota minimum wage, plus appropriate benefits.

3) Amount Requested: \$2,499.89

4) Describe the proposed project: \_\_\_\_\_

The funds would be used to replace a two door merchandiser cooler that has quit  
operating correctly. This cooler is used to display fresh fruits and vegetables available  
for purchase at the Grand Portage Trading Post. Replacing this cooler will provide  
continued access to fresh foods for the community.

5) Please attach the project budget, including sources and uses of funds.

6) Anticipated Completion Date: ASAP

7) How many jobs do you anticipate will be created or retained by this project?

Created: \_\_\_\_\_ Retained: 55-12 Total: \_\_\_\_\_

8) What is the proposed wage/salary of the jobs?

Hourly: \_\_\_\_\_ Salary: \_\_\_\_\_

↓  
confidential

(ms)



SFS Equipment LLC  
1209 County Road E Suite 102  
Arden Hills, MN 55112 US



## Estimate

**ADDRESS**

Grand Portage Lodge & Casino  
P.O. box 234  
72 Casino drive  
Grand Portage MN 55605

**SHIP TO**

Grand Portage Lodge &  
Casino  
P.O. box 234  
72 Casino drive  
Grand Portage MN 55605

**ESTIMATE #** 1359

**DATE** 03/19/2021

**SALES REP**

Alex Slind

**SALES REP PHONE #**

218-340-0747

DATE	ITEM CODE	DESCRIPTION	QTY	PRICE EACH	AMOUNT
03/19/2021	<b>Equipment</b>	NEW Aurora 2 door glass door merchandiser cooler 2 year parts and labor and 5 year compressor warranty	1	2,499.89	2,499.89

TOTAL

**\$2,499.89**

Accepted By

Accepted Date

17

All sales are final. 30% restocking fee on all returned items. Special orders cannot be returned. Gas, plumbing and electrical hook ups must be performed by a trained professional. Failure to do so voids warranty.



# GMR48

## Double Glass Door Refrigerator Merchandiser

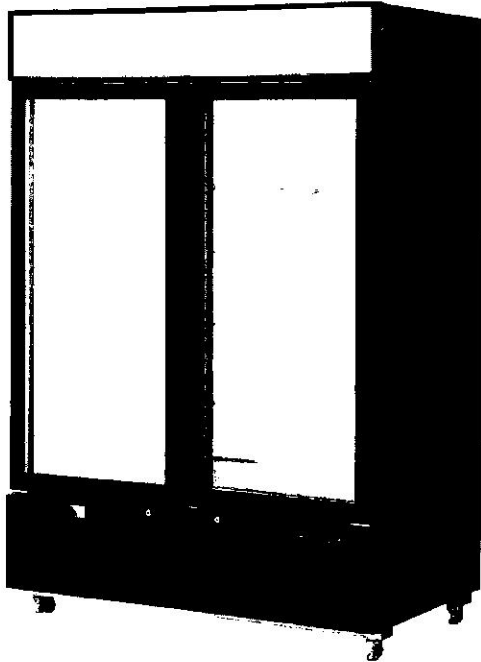

### Features:

- Available in black or white exterior
- Aluminum interior
- Stainless steel interior floor for easy cleaning
- Easy-clean PVC liner and quick change shelves
- Heavy duty evaporator fans
- Self-contained refrigeration with a fully ventilated cooling system
- Environmentally-friendly R134A refrigerant
- LED lights keep products illuminated
- Low E tempered double-pane glass and durable PVC frame
- Low-profile easy grab handles
- Top LED illuminated display sign for custom graphics
- Equipped with digital thermostat for accurate and stable temperature
- Oversized bottom back-mount condensing unit for faster cooling
- Positive-seal, self-closing doors with stay open feature



GMR48	
Doors	2
Capacity (Cu. Ft.)	47
Shelves	8
HP	1/3
Amps	4.3
Volts	115
Hz	60
Phase	1
Plug Type	NEMA 5-15
Dimensions	54.4"W x 31.5"D x 83.5"H
Shipping Dimensions	56.22"W x 33.07"D x 86.22"H
Shipping Weight (lb)	419
Net Weight (lb)	397

Double Glass Door Refrigerator Merchandiser | GMR48

# GMR48

Double Glass Door  
Refrigerator Merchandiser

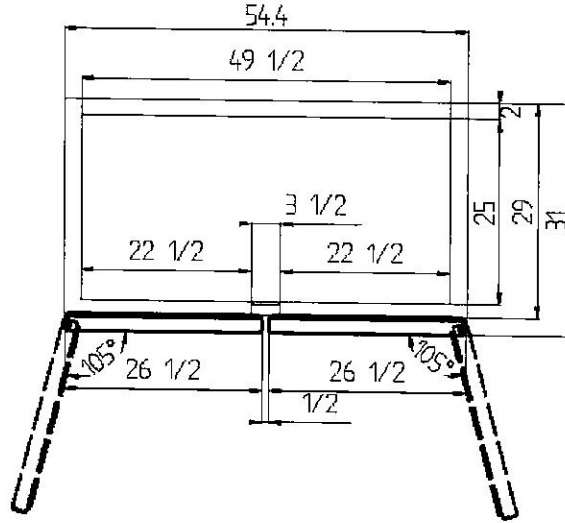

FBGM48F-W  
FBGM48-W  
FBGM48F-B  
FBGM48-B

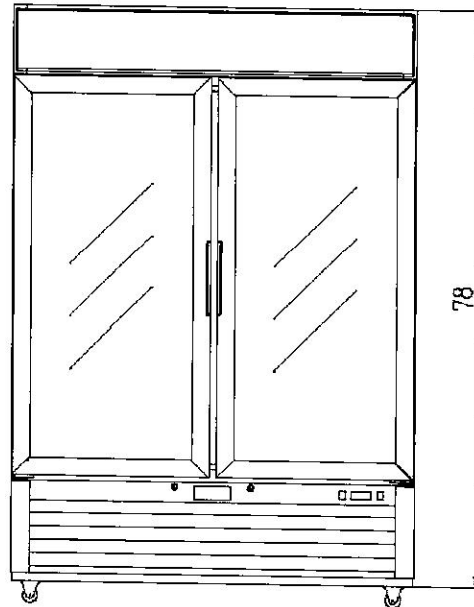

Alcom Distributing  
(701) 739-4479 | www.alcomdist.com

19

COOK COUNTY/GRAND MARAIS ECONOMIC DEVELOPMENT AUTHORITY  
RESOLUTION NO. 2021-01

STATE OF MINNESOTA  
COUNTY OF COOK  
COOK COUNTY/GRAND MARAIS ECONOMIC DEVELOPMENT AUTHORITY

RESOLUTION AUTHORIZING  
COOK COUNTY/GRAND MARAIS ECONOMIC DEVELOPMENT AUTHORITY  
TO MAKE APPLICATION TO AND ACCEPT FUNDS FROM  
IRRR COMMERCIAL REDEVELOPMENT GRANT PROGRAM

WHEREAS THE authorizing authority approves of the attached application for the Metis Housing project; and

WHEREAS THE authorizing authority agrees to accept funding for the underlying project if approved by IRRR;

NOW BE IT RESOLVED that the authorizing authority of the Cook County/Grand Marais Economic Development Authority does adopt this resolution.

Upon vote taken, the following voted:

For:

Against:

Whereupon said Resolution No. 2021-01 was declared duly passed and adopted this 6<sup>th</sup> day of April 2021.

\_\_\_\_\_  
Name #1

\_\_\_\_\_  
Name #2

\_\_\_\_\_  
Title #1

\_\_\_\_\_  
Title #2

COOK COUNTY/GRAND MARAIS ECONOMIC DEVELOPMENT AUTHORITY  
RESOLUTION NO. 2021-02

STATE OF MINNESOTA  
COUNTY OF COOK  
COOK COUNTY/GRAND MARAIS ECONOMIC DEVELOPMENT AUTHORITY

RESOLUTION AUTHORIZING  
COOK COUNTY/GRAND MARAIS ECONOMIC DEVELOPMENT AUTHORITY  
TO MAKE APPLICATION TO AND ACCEPT FUNDS FROM  
IRRR DEVELOPMENT INFRASTRUCTURE GRANT PROGRAM

WHEREAS THE authorizing authority approves of the attached application for the Cook County Historical Society Archival Storage Facility project; and

WHEREAS THE authorizing authority agrees to accept funding for the underlying project if approved by IRRR;

NOW BE IT RESOLVED that the authorizing authority of the Cook County/Grand Marais Economic Development Authority does adopt this resolution.

Upon vote taken, the following voted:

For:

Against:

Whereupon said Resolution No. 2021-02 was declared duly passed and adopted this 6<sup>th</sup> day of April 2021.

\_\_\_\_\_  
Name #1

\_\_\_\_\_  
Name #2

\_\_\_\_\_  
Title #1

\_\_\_\_\_  
Title #2



April 1, 2021

Dear Board Members

March was a busy month given all of the new programs available from President Biden's America Rescue Plan.

Through March 29<sup>th</sup> I booked 50.25 hours on Covid related counseling and 45 hours in business consulting in 139 different client sessions, either Zoom, phone or email.

I am actively involved in securing financing for three new business starts and working with two other clients on business plans.

I have been an active blogger keeping clients up to date on as many details as possible as SBA information changes frequently. My personal quest is to insure every venue in Cook County that qualifies for the Restaurant Revitalization Fund (RRF) knows about the program and is preparing to apply as soon as it opens. I have sent this information regardless of their client status and offered assistance. This action does not initially qualify as something I am paid to do, however I do ask them to register for services and two have.

And finally I have worked with the finance committee to present, organize and award loan funding to business clients through the revised Taconite Area Business Relief Program .

Thank You for supporting the Success(ion) Planning workshop. Seven local business owners participated and to a person found great value in the instruction, team interactions and workbook. I met with each owner twice during the 8 week session and I believe one will eventually sell her business yet this year!

I am vaccinated and am starting to see clients on site again. It would be great if there is budget money to install a printer in Mary's office. It would save me time.

Let me know if you have any questions.

Pat  
pcampanaro@gmail.com  
651-336-2964

FYI: I will be out of the office from May 1-9 visiting my son and Grands in NY!

22

**Director's Report**  
**April 6, 2021**

Meetings and activities are consistent with past Director's Reports.

Some items of note, since the March EDA meeting:

- Legislative update with Senator Bakk and Representative Ecklund and Chamber of Commerce
- CEC at GM City Council regarding ARAC grant application for public art project
- Interviews with candidates for superintendent position at Superior National
- Transfer EDA website to WA Fisher completed
- Closed on the sale of a lot at Cedar Grove to Cook County Historical Society
- Initial meeting of Housing Work Group, subcommittee of Joint Powers/Community Leaders
- Cancelled April trip to Jamaica
- Having been fully vaccinated, enjoying spring break with my grandchildren, hence this abbreviated Director's Report